

Power management Dual-transistors

DUAL TRANSISTOR (NPN+PNP)

DESCRIPTION

Silicon epitaxial planar transistor

FEATURES

- 2SA1037AK and 2SC2412K are housed independently in a package
- Transistor elements independent, eliminating interference
- Mounting cost and area can be cut in half

MARKING: Z1

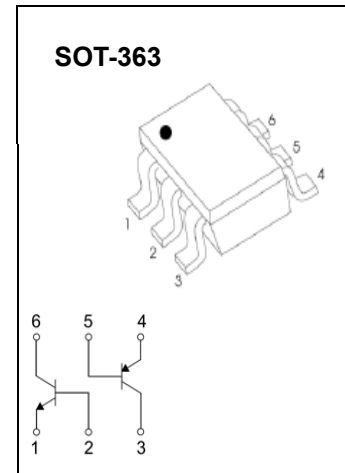
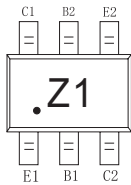

TR1 MAXIMUM RATINGS $T_a=25^{\circ}\text{C}$ unless otherwise noted

Symbol	Parameter	Value	Unit
V_{CBO}	Collector- Base Voltage	60	V
V_{CEO}	Collector-Emitter Voltage	50	V
V_{EBO}	Emitter-Base Voltage	7	V
I_C	Collector Current -Continuous	0.15	A
P_C	Collector Power Dissipation	0.15	W
T_J, T_{stg}	Operation Junction and Storage Temperature Range	-55~+150	$^{\circ}\text{C}$

TR2 MAXIMUM RATINGS $T_a=25^{\circ}\text{C}$ unless otherwise noted

Symbol	Parameter	Value	Unit
V_{CBO}	Collector- Base Voltage	-60	V
V_{CEO}	Collector-Emitter Voltage	-50	V
V_{EBO}	Emitter-Base Voltage	-6	V
I_C	Collector Current -Continuous	-0.15	A
P_C	Collector Power Dissipation	0.15	W
T_J, T_{stg}	Operation Junction and Storage Temperature Range	-55~+150	$^{\circ}\text{C}$

TR1 NPN ELECTRICAL CHARACTERISTICS (Ta=25°C unless otherwise specified)

Parameter	Symbol	Test conditions	Min	Typ	Max	Unit
Collector-base breakdown voltage	$V_{(BR)CBO}$	$I_C=50\mu A, I_E=0$	60			V
Collector-emitter breakdown voltage	$V_{(BR)CEO}$	$I_C=1mA, I_B=0$	50			V
Emitter-base breakdown voltage	$V_{(BR)EBO}$	$I_E=50\mu A, I_C=0$	7			V
Collector cut-off current	I_{CBO}	$V_{CB}=60V, I_E=0$			0.1	μA
Emitter cut-off current	I_{EBO}	$V_{EB}=7V, I_C=0$			0.1	μA
DC current gain	h_{FE}	$V_{CE}=6V, I_C=1mA$	120		560	
Collector-emitter saturation voltage	$V_{CE(sat)}$	$I_C=50mA, I_B=5mA$			0.4	V
Transition frequency	f_T	$V_{CE}=12V, I_C=2mA, f=100MHz$		180		MHz
Collector output capacitance	C_{ob}	$V_{CB}=12V, I_E=0, f=1MHz$		2.0	3.5	pF

TR1 PNP ELECTRICAL CHARACTERISTICS (Ta=25°C unless otherwise specified)

Parameter	Symbol	Test conditions	Min	Typ	Max	Unit
Collector-base breakdown voltage	$V_{(BR)CBO}$	$I_C=-50\mu A, I_E=0$	-60			V
Collector-emitter breakdown voltage	$V_{(BR)CEO}$	$I_C=-1mA, I_B=0$	-50			V
Emitter-base breakdown voltage	$V_{(BR)EBO}$	$I_E=-50\mu A, I_C=0$	-6			V
Collector cut-off current	I_{CBO}	$V_{CB}=-60V, I_E=0$			-0.1	μA
Emitter cut-off current	I_{EBO}	$V_{EB}=-6V, I_C=0$			-0.1	μA
DC current gain	h_{FE}	$V_{CE}=-6V, I_C=-1mA$	120		560	
Collector-emitter saturation voltage	$V_{CE(sat)}$	$I_C=-50mA, I_B=-5mA$			-0.5	V
Transition frequency	f_T	$V_{CE}=-12V, I_C=-2mA, f=100MHz$		140		MHz
Collector output capacitance	C_{ob}	$V_{CB}=-12V, I_E=0, f=1MHz$			5	pF

PACKAGE OUTLINE

Plastic surface mounted package; 3 leads

SOT-363

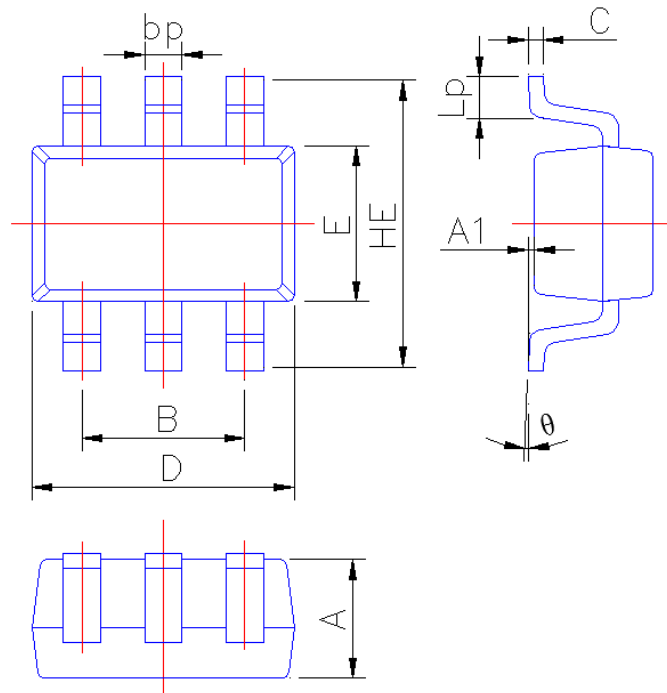

Symbol	Dimension in Millimeters	
	Min	Max
A	0.90	1.00
A1	0.010	0.100
B	1.20	1.40
bp	0.25	0.45
C	0.09	0.15
D	2.00	2.20
E	1.15	1.35
HE	2.15	2.55
Lp	0.25	0.46
θ	0°	6°